

## SPECIFICATION

Part No.: \_\_\_\_\_  
Customer: \_\_\_\_\_  
Date: \_\_\_\_\_

Written by	Checked by	Approval
FL Lai	PH Jiang	CK Chang

### ELECTRICAL SPECIFICATIONS

ITEM	Part 1	Part 2	Part 3	UNIT	
1	Center freq	772	807.5	856	MHz
2	Bandwidth [BW]	fo ±3 [769.0~775.0]	fo ±8.5[799.0~816.0]	fo ±5[851.0~861.0]	MHz
3	Insertion Loss in BW	3.0	3.0	3.0	dB max
4	Ripple in BW	1.0	1.0	1.0	dB max
5	VSWR in BW@ANT	1.5	1.5	1.5	max
6	Attenuation	50 min. @ [799~816] 50 min. @ [851~861]	60 min. @ [769~775] 50 min. @ [851~861]	60 min. @ [769~775] 60 min. @ [799~816]	dB min
7	Group Delay Variation				ns max
8	Input Power	3.0			W
9	In/Out Impedance	50Ω			Ω
10	Operation Temperature Range	-40°C to +85°C			°C

### MECHANICAL SPECIFICATIONS

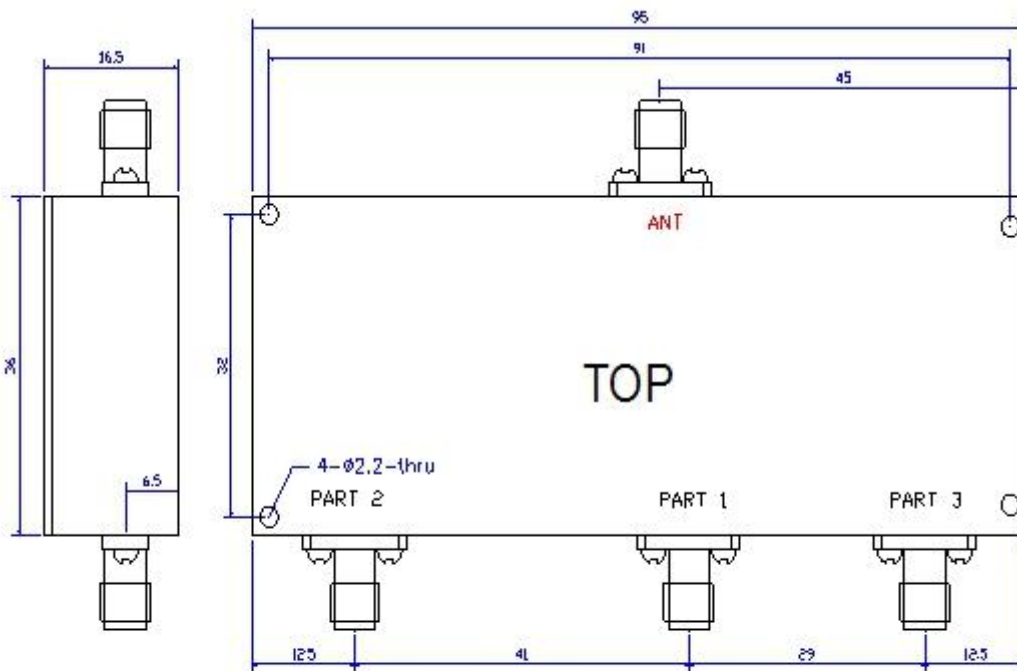

TOL:±0.2  
UNIT:mm